

KUGOO M4 Pro

User's Manual



Disclaimer

Under no circumstances, including but not limited to negligence, shall our distributor be liable for any special or consequential damages that result from the inability to use the materials in this manual, even if we have been advised of the possibility of such damages.

Applicable law may not allow the limitation or exclusion of liability or incidental or consequential damages, so the above limitation or exclusion may not apply to you.

Main Parts of the Scooter

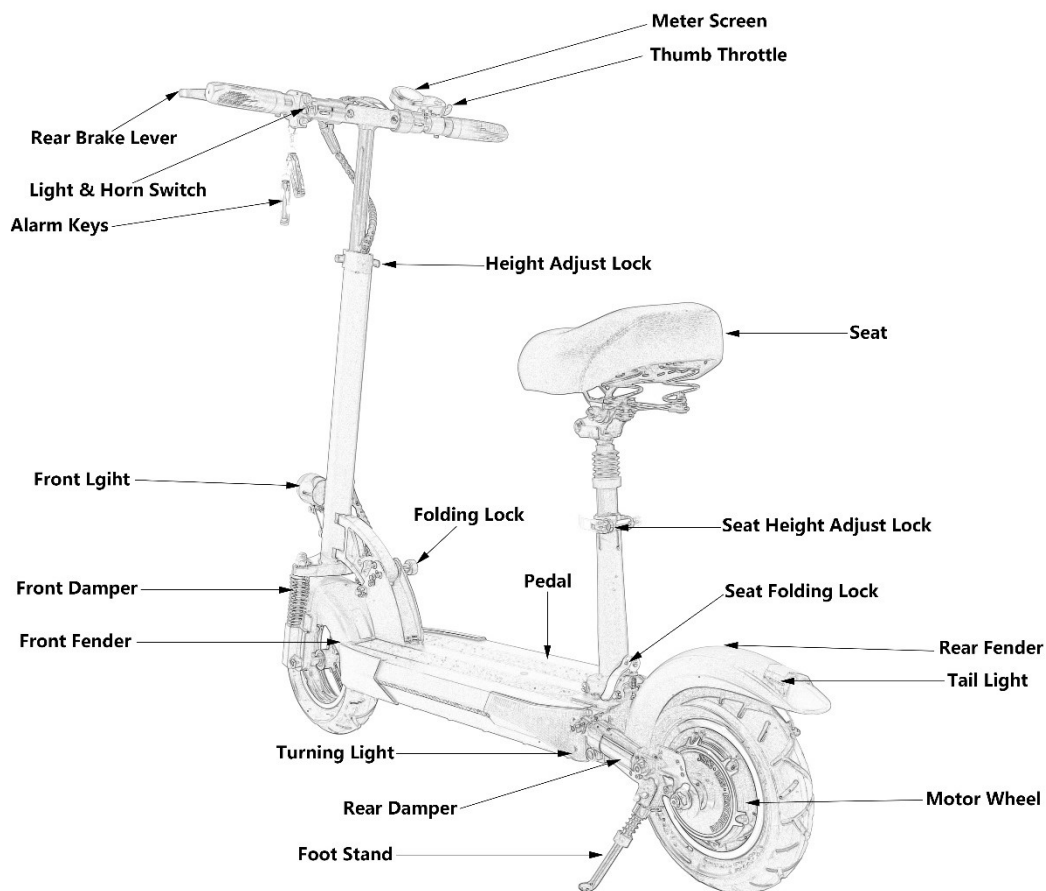

Folding the Scooter

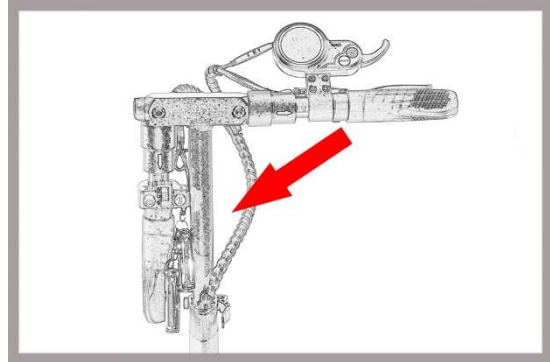
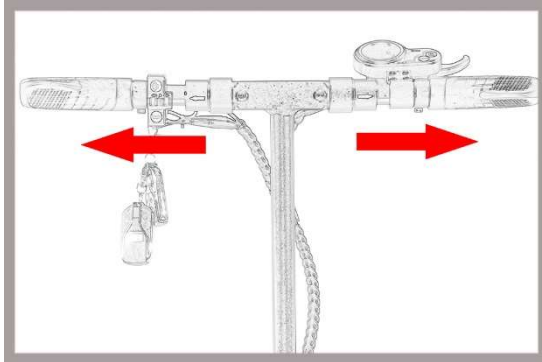

1. Lock out the Handlebar
2. Folding the Handlebar
3. Take out the Folding Lock and Folding the Scooter

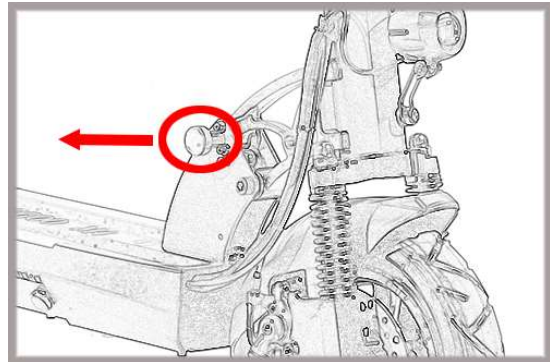

Charging the Scooter

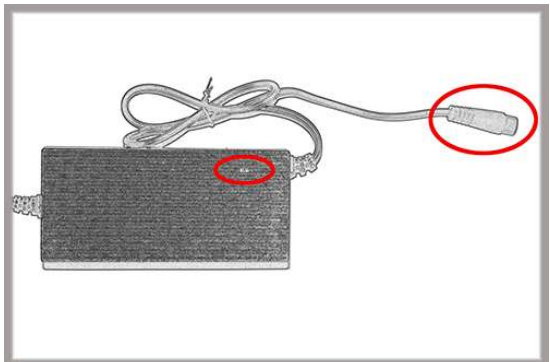
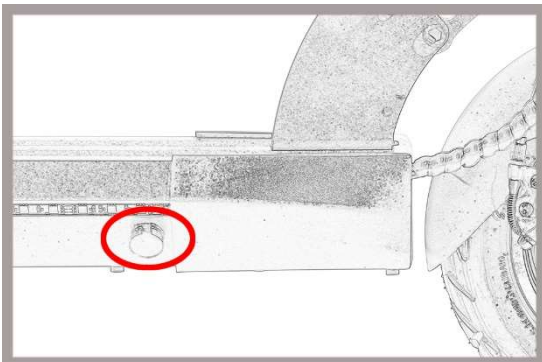

1. Take out the Charger Port Cap
2. Connect the Plug
3. Red light means charging; Green light means charge-full or disconnected.

How to Ride

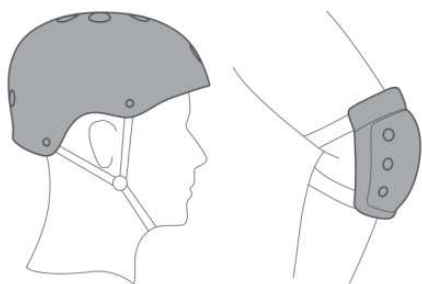

Wear helmets and knee pads at all times in case of falls and injuries

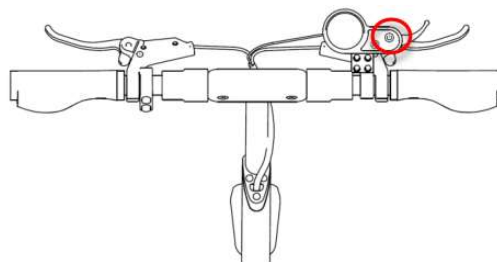

Press and hold the power button to turn on the scooter

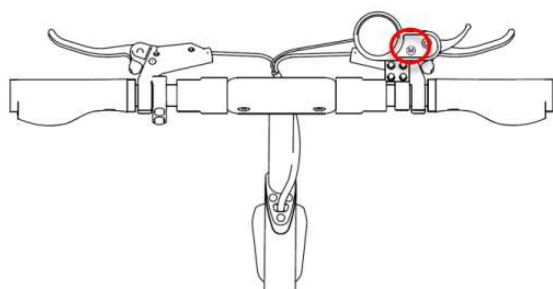

Tap the mode button to toggle between power levels

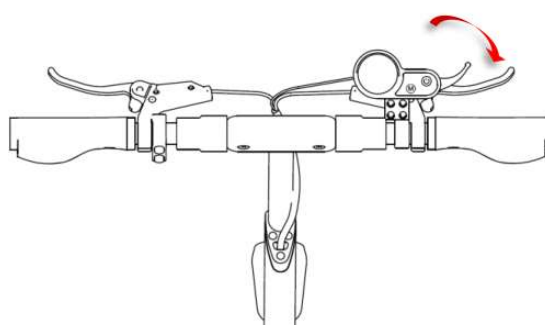

Lightly pull on the throttle to engage the motor

Ride Safety

1. Ensure all parts are tightly fitted and secure before you ride;
2. Ensure a safe speed when the scooter driving on bumpy uneven surfaces;
3. Don't accelerate when travelling downhill;
4. Don't use the accelerator when pushing the scooter;
5. Don't hang anything from the handlebar of the scooter;
6. Don't ride through puddles;
7. Don't ride with anyone on the scooter including children;
8. Don't put your feet on rear dampers or fenders.

Meter Button and Function

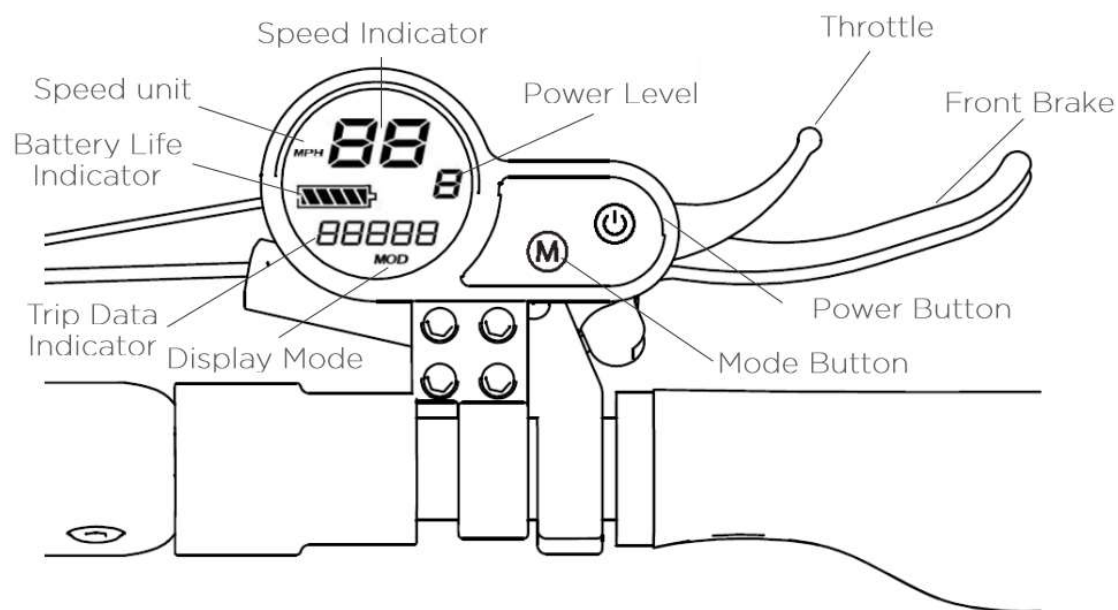

Main Mode Selection

1. Press and hold the power button 2-3 seconds to switch on the scooter
2. Tap the MODE button to toggle between the 3 levels gears (1 < 2 < 3)
3. Tap the power button to display and switch the screen..

English acronyms on the screen:

ODO	Total Mileage
TRIP	Current Trip Mileage
VOLT	Battery Voltage in Time
CURRENT	Output Current in Time
ERROR	Error Data
TIME	Time Elapsed

Using the Remote System

1. The scooter comes with an anti-theft function.
2. When the scooter is turned off, simply press the lock button and the anti-theft function will be activated.
3. The scooter will sound an alarm when it vibrates or moves you can turn off the anti-theft function and turn off the alarm by pressing the unlock button.
4. If the scooter is locked, the motor will not work. Please press the unlock button and turn on the scooter from the meter.
5. Press the power button twice that the scooter will be power on, but also you need turn the scooter on from the meter for riding.
6. You can search the scooter with its panic button when you are confused about where you parked the scooter. Just press it and it will start sounding an alarm so you can locate the scooter. This alarm will turn off on its own within 5 seconds.

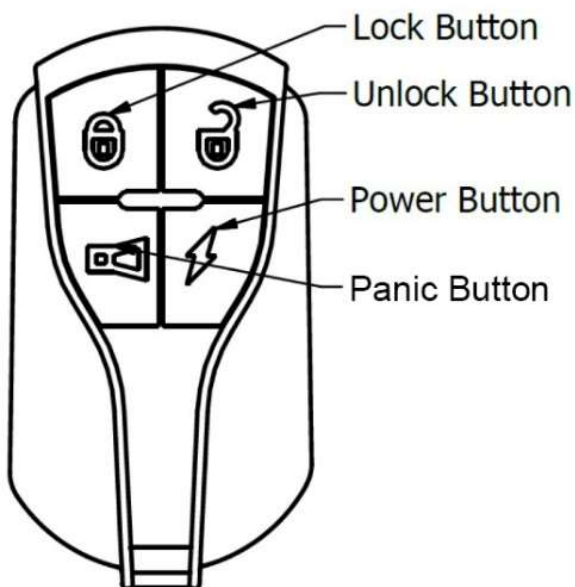

Headlights and Horn

The scooter is equipped with a headlight and a horn which can easily be activated from the dashboard.

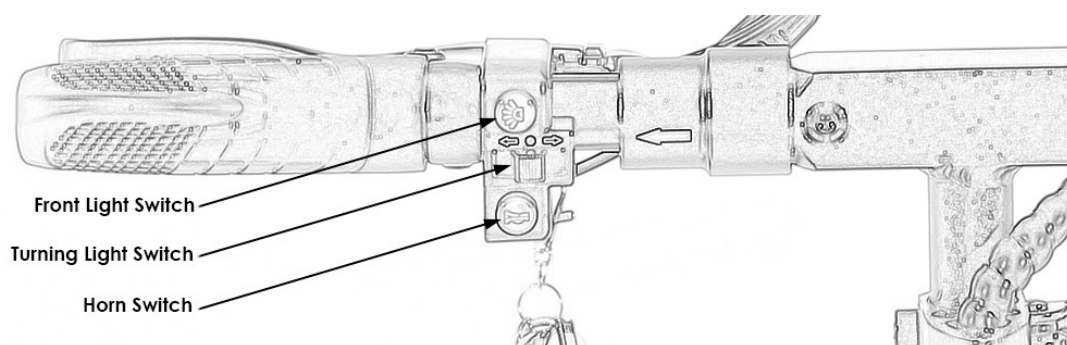

Safety Reminder

1. This electric scooter is a leisure device. But once in a public area, they'll be vehicles, subject to risks faced by all vehicles. For your safety, please follow instructions in the manual.
2. Make sure you follow and are aware of traffic laws, regulations or restrictions set forth by your local government and regulatory agencies.
3. Check the scooter before every use. When you note loosen parts, low battery alerts, flat tires, excessive wear, strange sounds, malfunctions and other abnormal conditions, stop riding immediately.
4. Others may also pose a risk to your safety by careless or inappropriate driving. Make sure to be aware of your surroundings and never ride under the influence of drugs or alcohol.
5. Respect pedestrians' right of way try not to startle them and use caution when approaching them from behind.
6. The faster you ride the longer your braking time. On smooth surfaces the scooter may slip, lose balance and may result in a fall. Always maintain a safe distance between others and obstacles.
7. Don't lend the scooter to anyone who does not know how to use it safely, please take the time and responsibility to ensure he/she knows how to operate the vehicle and wears the safety gear.
8. Please follow the safety instructions in the manual and any rules or regulation in your jurisdiction. We shall not be liable for any financial losses, physical injuries, accidents, legal disputes and other conflicts that arise from actions that violate user instruction.

Daily Care and Maintenance

1. Use a damp cloth to clean and remove stains from the scooter. If needed an abrasive material such as sandpaper can be used to lightly polish the scooter. Don't use alcohol, kerosene or any other corrosive material to clean the scooter.
2. When the scooter is not in use, keep it indoors in a dry and cool environment.
3. Use original battery packs, use of other brands may result in damage or fire.
4. Don't touch the battery contacts, do not dismantle or puncture, ensure contacts are far away from metal objects to avoid a short-circuit.
5. Store the battery at about 40%-60% charge ensure the battery is not left in an environment above 50°C or below -20°C.

Technical Table

ITEM	SPECIFICATION
Motor Power	48V, 500W
Battery Packs	48V 16Ah Lithium-ion Internal Battery Management System
Controller	42V to 54.6V Sine Wave, 21A Limited Output
Lights	Front LED Light, Rear Brake Light
Brake	Mechanical Disc Brake Power Off Brake
Dampers	Dual Spring Dampers both Front and Rear
Wheels	10" Pneumatic Tires
Charging Time	8 Hours
Max. Speed:	45 Km/h
Max. Loading:	150 Kg
Max. Range:	60 Km
Max. Climbing	Approx. 14%
Dimensions	Unfolded:115x116x41.5 cm Folded:115x41.5x23.5 cm
Item Weight	23.6 Kg

Warranty

We guarantee each new scooter frame against defects in workmanship and materials for one year. All original components are also covered by warranty for a period of one year from the date of purchase, but half a year for the battery pack. This warranty is expressly limited to the replacement of a defective frame, or defective parts and is the sole remedy of the warranty. This warranty applies only to original owners and is not transferable. Claims under this warranty must be made directly to the place where you purchased the scooter, and proof of purchase is required, this warranty does not cover normal wear and tear, improper assembly or follow-up maintenance, or installation of parts or accessories. The warranty does not apply to damage or failure due to accident, misuse, abuse, or neglect. Modification of the frame or components shall void this warranty.

Caution

As with all mechanical components, kick scooters are subjected to wear and tear, as well as high stresses. Different materials and components may fatigue in different ways. If the design life of a component has been exceeded, it can suddenly fail, possibly causing injuries to the rider. Any form of crack, scratches or change of coloring can indicate that the life of the components has been reached and should be replaced.

The scooter must comply with your countries legal requirements when riding on public roads and in all conditions, including bad weather, night time, dusk or dawn. Many countries require specific safety devices. It is your responsibility to familiarize yourself with the laws of the country where you ride and to comply with all applicable laws including properly equipping yourself and the scooter as the law requires.